

THIS DRAWING IS UNPUBLISHED. RELEASED FOR PUBLICATION
 © COPYRIGHT BY TYCO ELECTRONICS CORPORATION. ALL RIGHTS RESERVED.

LOC	DIST	REVISIONS					
FT	0	P	LTR	DESCRIPTION	DATE	DWN	APVD
		B		REVISED PER 0G3B-0144-05	3/4/05	SS	SRY

NOTES:
MATERIAL:
 HOUSING: THERMOPLASTIC, UL94V-0, BLACK.
 TERMINALS: BRIGHT TIN OVER COPPER ALLOY.
 SCREWS: 6-32, STEEL, ZINC PLATING W/ CLR CHROMATE.
ELECTRICAL:
 CURRENT RATING: 20A.
 OPERATING VOLTAGE: 300V.
 WIRE RANGE: 12-22 AWG.
ENVIRONMENTAL:
 OPERATING TEMP.: 105°C MAX.

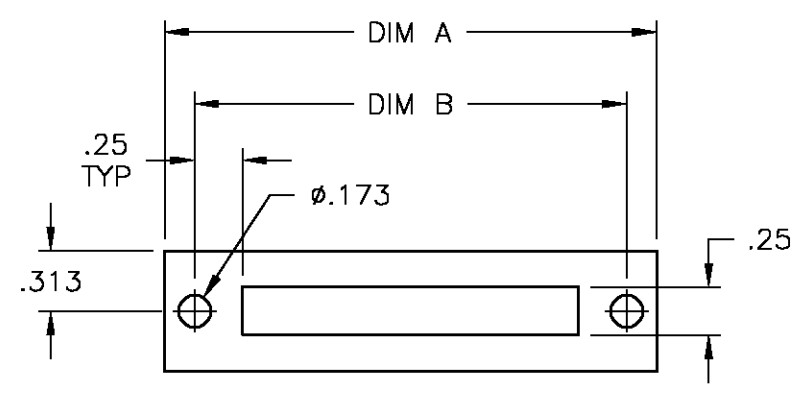
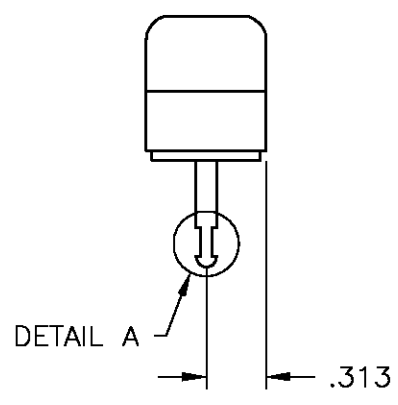
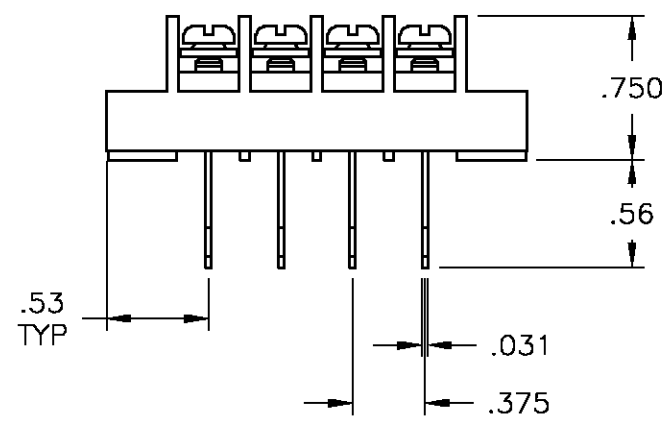
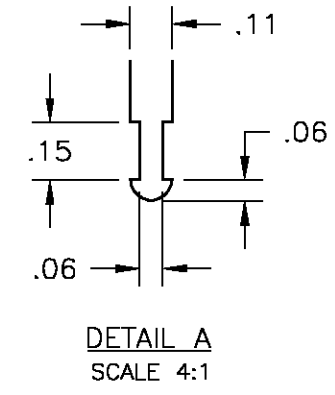
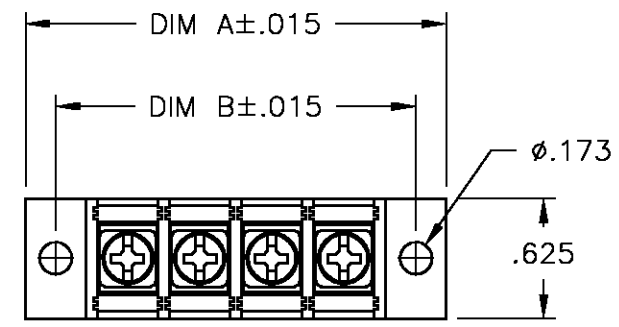

9.000	9.314	23	JC6-T208-23	2-1546840-3
8.625	8.939	22	JC6-T208-22	2-1546840-2
8.250	8.564	21	JC6-T208-21	2-1546840-1
7.875	8.189	20	JC6-T208-20	2-1546840-0
7.500	7.814	19	JC6-T208-19	1-1546840-9
7.125	7.439	18	JC6-T208-18	1-1546840-8
6.750	7.064	17	JC6-T208-17	1-1546840-7
6.375	6.689	16	JC6-T208-16	1-1546840-6
6.000	6.314	15	JC6-T208-15	1-1546840-5
5.625	5.939	14	JC6-T208-14	1-1546840-4
5.250	5.564	13	JC6-T208-13	1-1546840-3
4.875	5.189	12	JC6-T208-12	1-1546840-2
4.500	4.814	11	JC6-T208-11	1-1546840-1
4.125	4.439	10	JC6-T208-10	1-1546840-0
3.750	4.064	9	JC6-T208-09	1546840-9
3.375	3.689	8	JC6-T208-08	1546840-8
3.000	3.314	7	JC6-T208-07	1546840-7
2.625	2.939	6	JC6-T208-06	1546840-6
2.250	2.564	5	JC6-T208-05	8-1437665-6
1.875	2.189	4	JC6-T208-04	8-1437665-5
1.500	1.814	3	JC6-T208-03	796985-1
1.125	1.439	2	JC6-T208-02	8-1437665-4

THIS DRAWING IS A CONTROLLED DOCUMENT.		DWN S SCHLEGEL 7/9/04	BUCHANAN Tyco Electronics Corporation Harrisburg, Pa 17105-3608			
DIMENSIONS: INCHES		CHK S YODER 7/9/04				
TOLERANCES UNLESS OTHERWISE SPECIFIED:		APVD S YODER 7/9/04	NAME JC6-T208-XX ASSEMBLY			
0 PLC ± - 1 PLC ± - 2 PLC ± .02 3 PLC ± .010 4 PLC ± - ANGLES ± -		PRODUCT SPEC -	APPLICATION SPEC -			
MATERIAL		WEIGHT	SIZE A3	CAGE CODE 00779	DRAWING NO C-8-1437665-4	RESTRICTED TO -
CUSTOMER DRAWING			SCALE NTS	SHEET 1 OF 1	REV B	